



2024
ENG Forest Trailers
for Tractors & ATV-s



BUILT TO LAST!

ABOUT THE COMPANY

COUNTRY forestry machinery

We produce forest trailers equipped with cranes for transporting wood by tractors or ATV-s.

Our goal is to offer our clients lasting technical solutions and to enhance our products in cooperation with the customers. The relation with our customers, whose satisfaction we value a lot, is based on mutual loyalty and trust.

We approach each client individually and offer them tailor-made solutions. Often a product is purchased with an aim to use it with an existing trailer, wood splitter or chipper. In that case we adjust the crane to fit the existing equipment.

We use in our production the highest quality European components and special steels.

The product line of COUNTRY is growing constantly. New models with improved technical solutions are released continuously. We are always a step ahead from the needs of our clients.

Country team

PRODUCT RANGE

Smart series

Lightweight, efficient and durable trailers equipped with cranes are designed for small tractors or ATV-s. Their light weight spares forest ground and vegetation.

Master series

MASTER series is designed for forest owners and farmers. This affordable but at the same time efficient and durable crane can be used also for different types of farm works.

Pro series

PRO series professional trailers equipped with cranes are designed specifically for daily transportation of logs. The reliable and durable PRO series cranes last intense load even in extremest conditions.

Table of contents



CRANE 410 Smart	4
CRANE 500 Smart	5
CRANE 430 Master	6
CRANE 550 Master	7
CRANE 670 Master	8
CRANE 700 Pro	9
CRANE 720 Pro	10
CRANE 750 Pro	11
CRANE 850 Pro	12
CRANE 950 Pro	13



Trailers technical specifications	14-15
Cranes technical specifications	14

TRAILER 15S / 30S	16
TRAILER 50S / 70S	17
TRAILER 90D / 110D	18
TRAILER 90S / 110S	19
TRAILER 110DU / 90SU	20
TRAILER 130D / 150D	21
TRAILER 130DU / 150DU	22

Cranes and trailers compatibility	23
Accessories	24
Grapples	25
Control valves	26

COUNTRY 
Smart Series

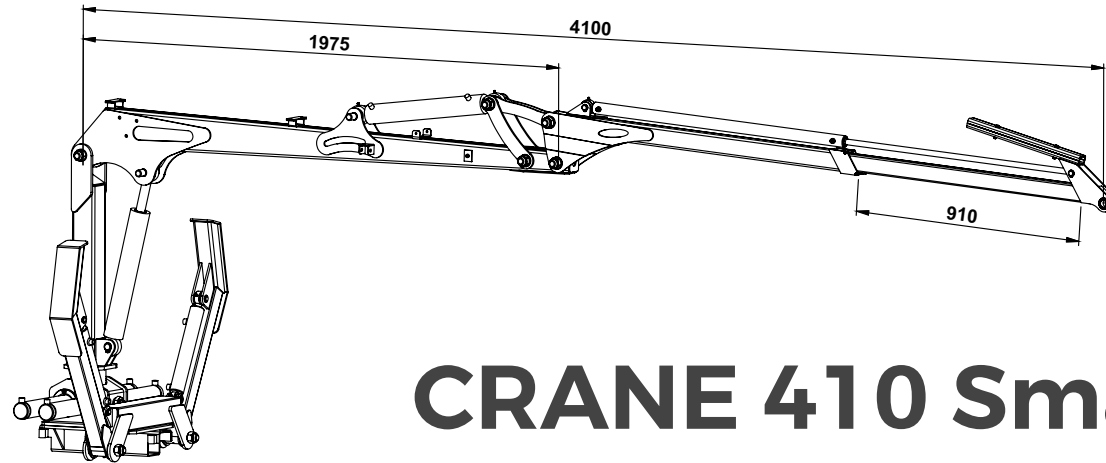
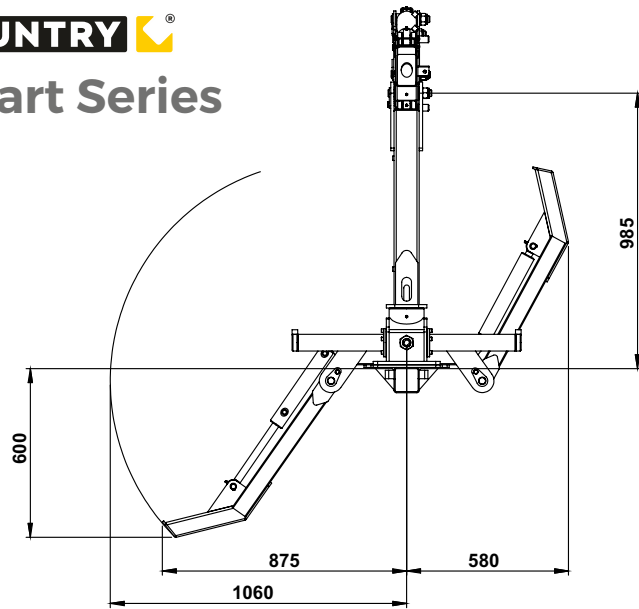

CRANE 410 Smart



	410 Smart
Max reach (m)	4.1
Lifting torque gross (kNm)	12
Lifting capacity at 3,5 m w/o rotator and grapple (kg)	280
Lifting capacity at full reach w/o rotator and grapple (kg)	180
Slewing torque (kNm)	2 or 4
Slewing cylinders (pcs)	2 or 4
Slewing angle	360
Rotator max axial load (kN)	10
Telescope extension (pcs)	1
Telescopic boom stroke length (m)	0.9
Working pressure (bar)	175
Crane's weight without support legs and valve block (kg)	167
Recommended pump capacity (l/min)	5-15
Support legs type	FD
A type (telescopic) support legs weight, kg	-
FD type SMART (flap down) support legs weight, kg	60
FD type MASTER (flap down) support legs weight, kg	-
FD type PRO (flap down) support legs weight, kg	-
Recommended grapple size (m ²)	0.08

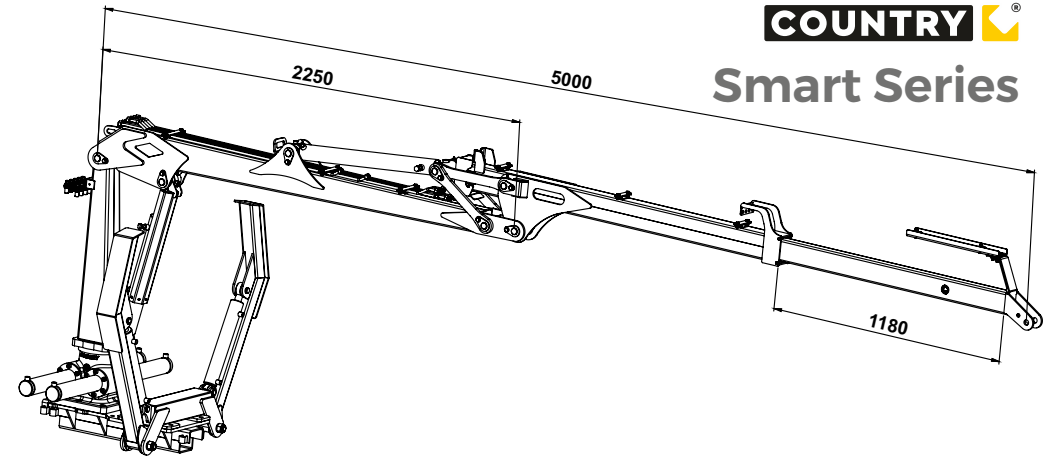
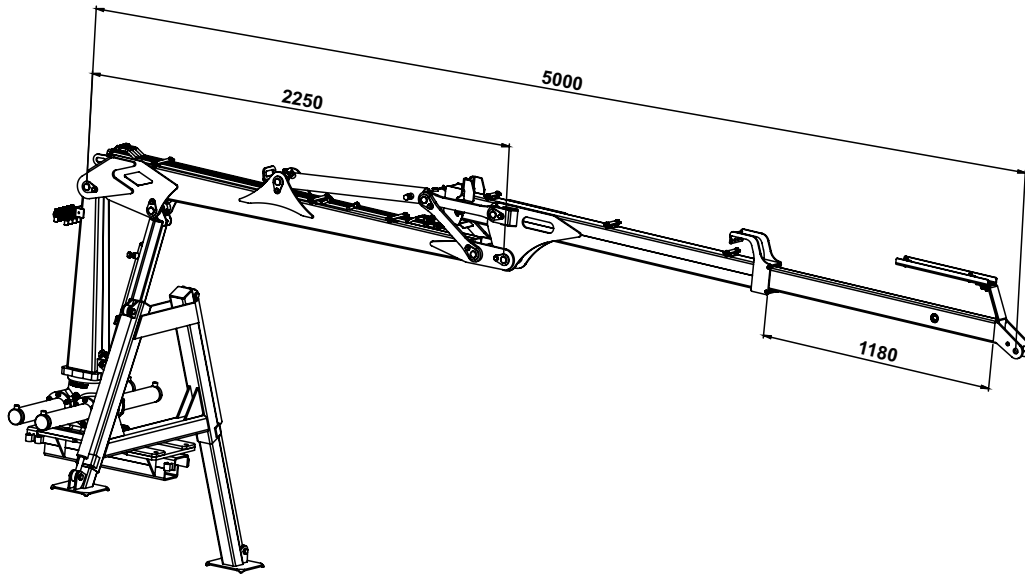

CRANE 500 Smart

	500 Smart
Max reach (m)	5.0
Lifting torque gross (kNm)	23
Lifting capacity at 3,5 m w/o rotator and grapple (kg)	550
Lifting capacity at full reach w/o rotator and grapple (kg)	382
Slewing torque (kNm)	6.3
Slewing cylinders (pcs)	4
Slewing angle	370
Rotator max axial load (kN)	30
Telescope extension (pcs)	1
Telescopic boom stroke length (m)	1.1
Working pressure (bar)	180
Crane's weight without support legs and valve block (kg)	315
Recommended pump capacity (l/min)	15-30
Support legs type	A or FD
A type (telescopic) support legs weight, kg	92
FD type SMART (flap down) support legs weight, kg	91
FD type MASTER (flap down) support legs weight, kg	-
FD type PRO (flap down) support legs weight, kg	-
Recommended grapple size (m2)	0.12



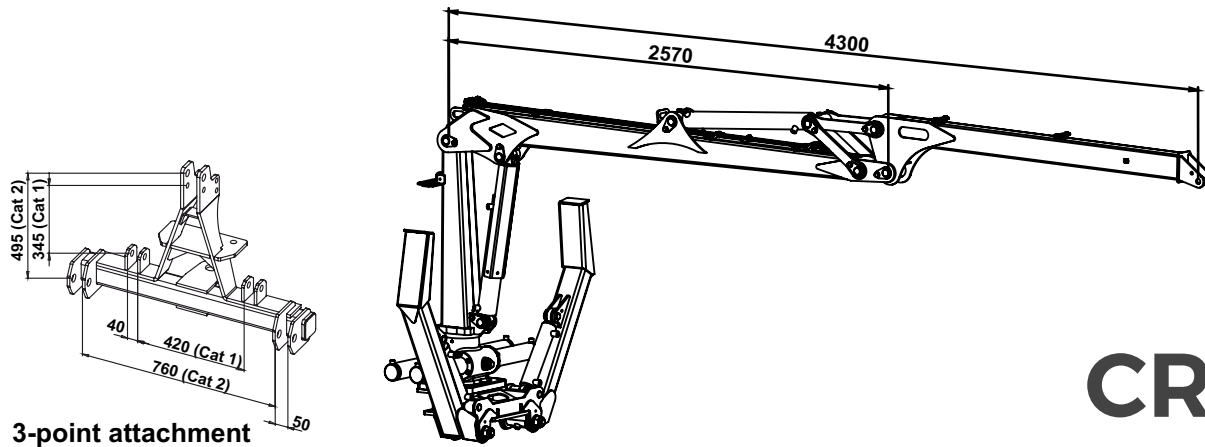

CRANE 430 Master



	430 Master
Max reach (m)	4.3
Lifting torque gross (kNm)	27
Lifting capacity at 3,5 m w/o rotator and grapple (kg)	660
Lifting capacity at full reach w/o rotator and grapple (kg)	538
Slewing torque (kNm)	7.8
Slewing cylinders (pcs)	4
Slewing angle	370
Rotator max axial load (kN)	30
Telescope extension (pcs)	-
Telescopic boom stroke length (m)	-
Working pressure (bar)	180
Crane's weight without support legs and valve block (kg)	335
Recommended pump capacity (l/min)	20-35
Support legs type	FD
A type (telescopic) support legs weight, kg	-
FD type SMART (flap down) support legs weight, kg	-
FD type MASTER (flap down) support legs weight, kg	135
FD type PRO (flap down) support legs weight, kg	-
Recommended grapple size (m2)	0.12 to 0.17

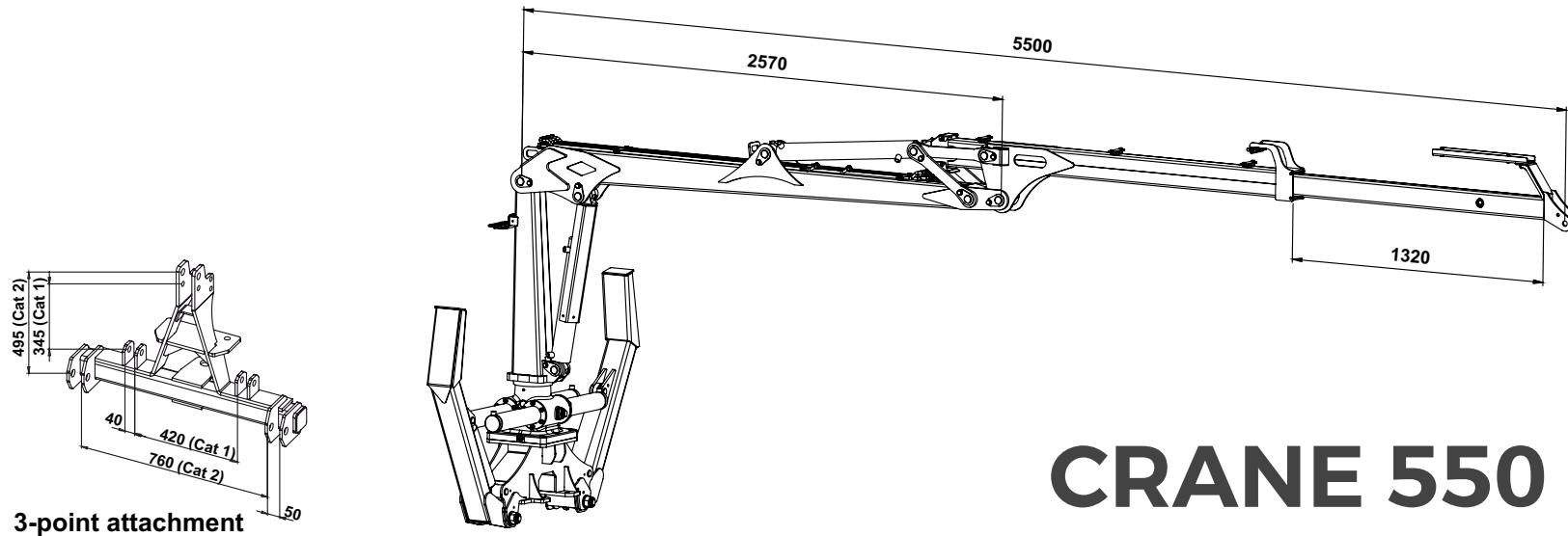

CRANE 550 Master

	550 Master
Max reach (m)	5.5
Lifting torque gross (kNm)	27
Lifting capacity at 3,5 m w/o rotator and grapple (kg)	618
Lifting capacity at full reach w/o rotator and grapple (kg)	390
Slewing torque (kNm)	7.8
Slewing cylinders (pcs)	4
Slewing angle	370
Rotator max axial load (kN)	30
Telescope extension (pcs)	1
Telescopic boom stroke length (m)	1.3
Working pressure (bar)	180
Crane's weight without support legs and valve block (kg)	375
Recommended pump capacity (l/min)	20-35
Support legs type	FD
A type (telescopic) support legs weight, kg	-
FD type SMART (flap down) support legs weight, kg	-
FD type MASTER (flap down) support legs weight, kg	135
FD type PRO (flap down) support legs weight, kg	-
Recommended grapple size (m2)	0.12 to 0.17



Master Series

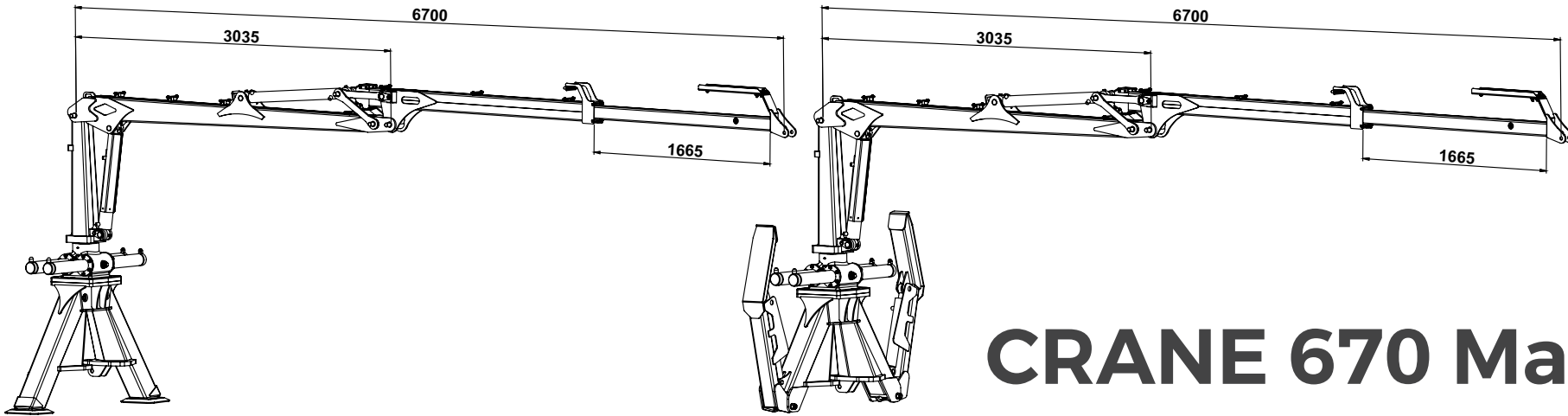

CRANE 670 Master



	670 Master
Max reach (m)	6.7
Lifting torque gross (kNm)	39
Lifting capacity at 3,5 m w/o rotator and grapple (kg)	870
Lifting capacity at full reach w/o rotator and grapple (kg)	451
Slewing torque (kNm)	12
Slewing cylinders (pcs)	4
Slewing angle	380
Rotator max axial load (kN)	30
Telescope extension (pcs)	1
Telescopic boom stroke length (m)	1.7
Working pressure (bar)	190
Crane's weight without support legs and valve block (kg)	565
Recommended pump capacity (l/min)	30-45
Support legs type	A or FD
A type (telescopic) support legs weight, kg	319
FD type SMART (flap down) support legs weight, kg	-
FD type MASTER (flap down) support legs weight, kg	338
FD type PRO (flap down) support legs weight, kg	420
Recommended grapple size (m2)	0.17 to 0.22

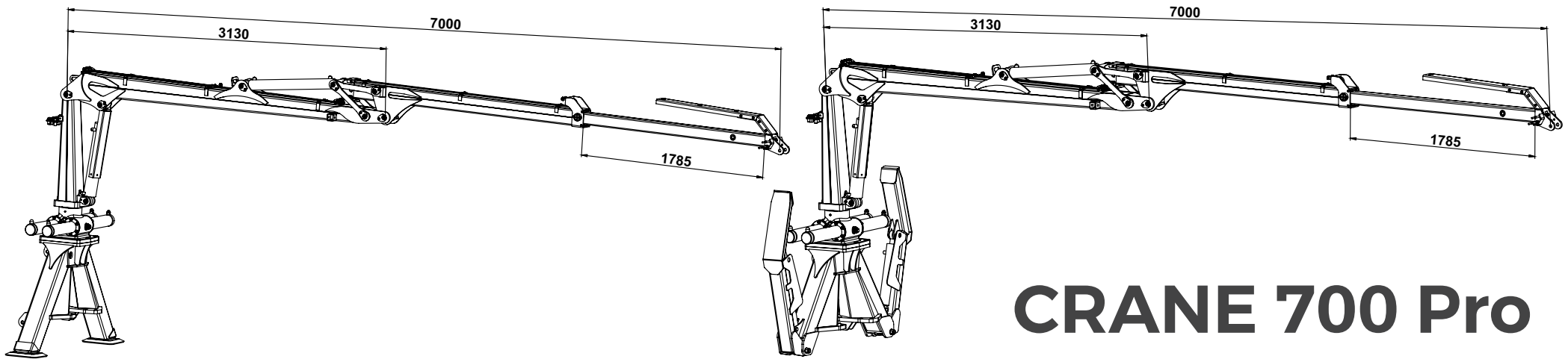

CRANE 700 Pro

	700 Pro
Max reach (m)	7.0
Lifting torque gross (kNm)	50
Lifting capacity at 3,5 m w/o rotator and grapple (kg)	1120
Lifting capacity at full reach w/o rotator and grapple (kg)	560
Slewing torque (kNm)	15
Slewing cylinders (pcs)	4
Slewing angle	380
Rotator max axial load (kN)	40
Telescope extension (pcs)	1
Telescopic boom stroke length (m)	1.8
Working pressure (bar)	190
Crane's weight without support legs and valve block (kg)	690
Recommended pump capacity (l/min)	40-55
Support legs type	A or FD
A type (telescopic) support legs weight, kg	319
FD type SMART (flap down) support legs weight, kg	-
FD type MASTER (flap down) support legs weight, kg	338
FD type PRO (flap down) support legs weight, kg	420
Recommended grapple size (m2)	0.22 to 0.26



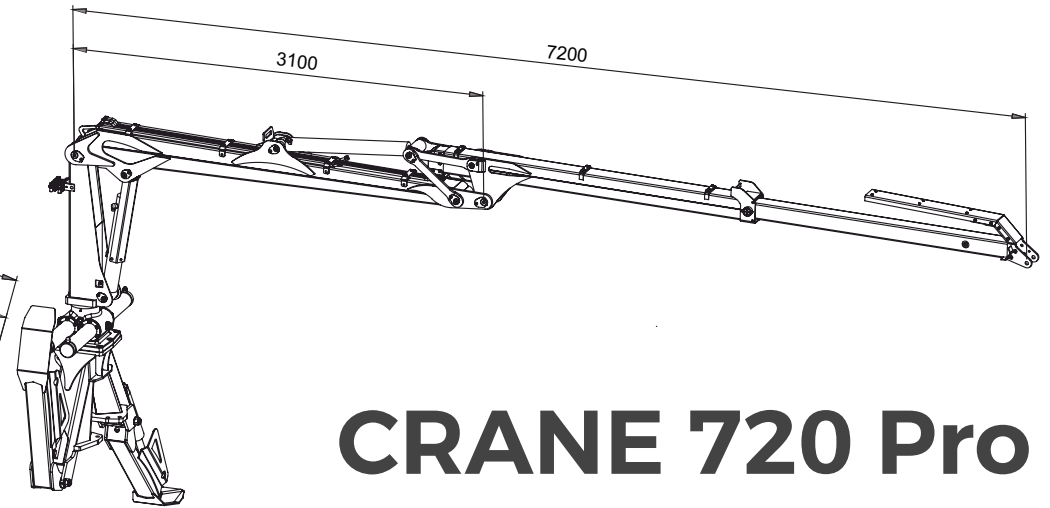
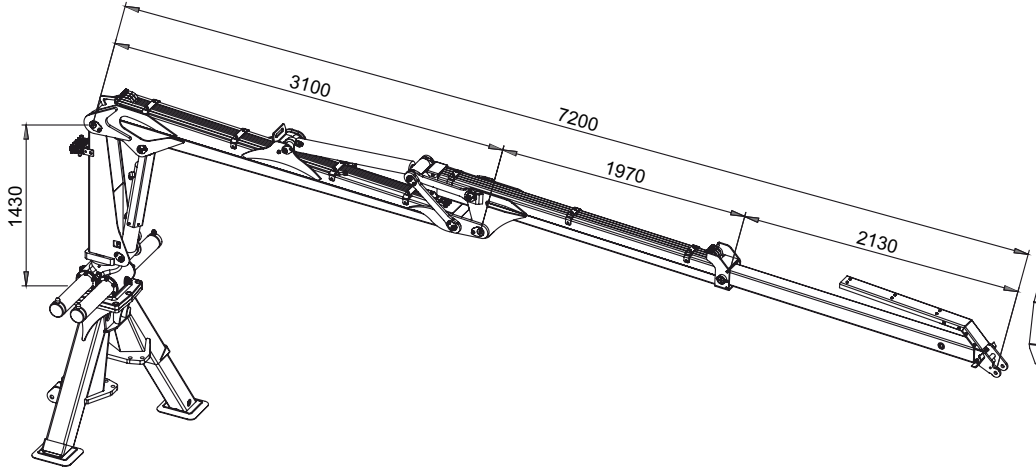

CRANE 720 Pro



	720Pro
Max reach (m)	7.2
Lifting torque gross (kNm)	57
Lifting capacity at 3,5 m w/o rotator and grapple (kg)	1356
Lifting capacity at full reach w/o rotator and grapple (kg)	625
Slewing torque (kNm)	16
Slewing cylinders (pcs)	4
Slewing angle	380
Rotator max axial load (kN)	40
Telescope extension (pcs)	1
Telescopic boom stroke length (m)	2.1
Working pressure (bar)	190
Crane's weight without support legs and valve block (kg)	780
Recommended pump capacity (l/min)	50-65
Support legs type	A or FD Pro
A type (telescopic) support legs weight, kg	319
FD type SMART (flap down) support legs weight, kg	-
FD type MASTER (flap down) support legs weight, kg	-
FD type PRO (flap down) support legs weight, kg	420
Recommended grapple size (m2)	0.22 to 0.26

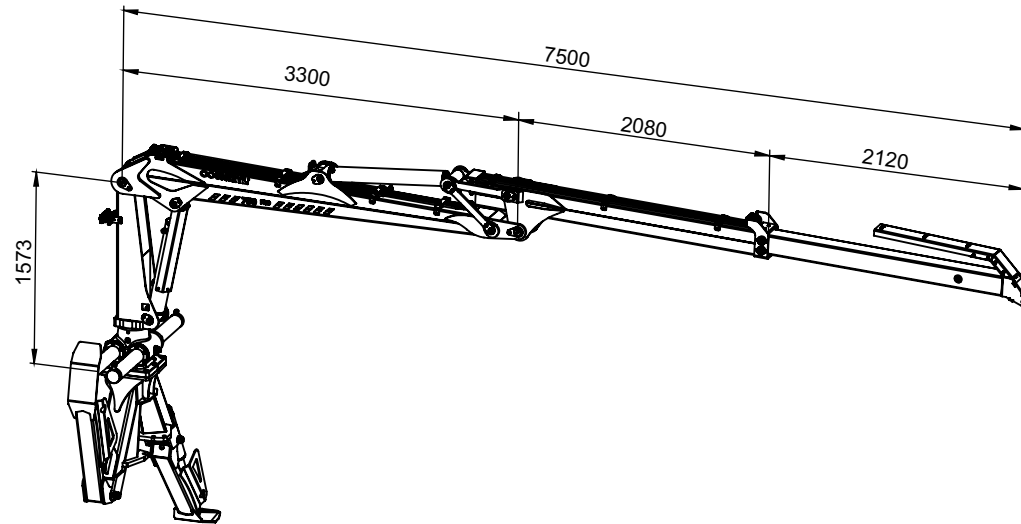

CRANE 750 Pro

	750Pro
Max reach (m)	7.5
Lifting torque gross (kNm)	86
Lifting capacity at 3,5 m w/o rotator and grapple (kg)	1898
Lifting capacity at full reach w/o rotator and grapple (kg)	886
Slewing torque (kNm)	21,5
Slewing cylinders (pcs)	4
Slewing angle	380
Rotator max axial load (kN)	55
Telescope extension (pcs)	1
Telescopic boom stroke length (m)	2,1
Working pressure (bar)	200
Crane's weight without support legs and valve block (kg)	1121
Recommended pump capacity (l/min)	60-100
Support legs type	FD Pro
A type (telescopic) support legs weight, kg	-
FD type SMART (flap down) support legs weight, kg	-
FD type MASTER (flap down) support legs weight, kg	-
FD type PRO (flap down) support legs weight, kg	420
Recommended grapple size (m ²)	0,26



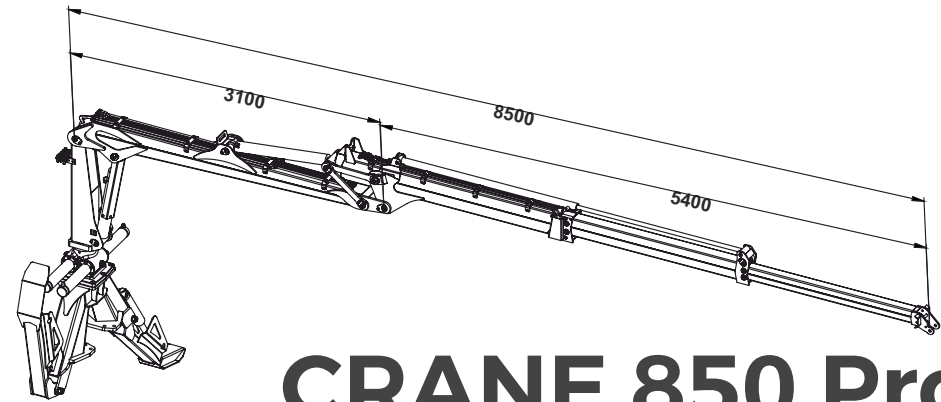
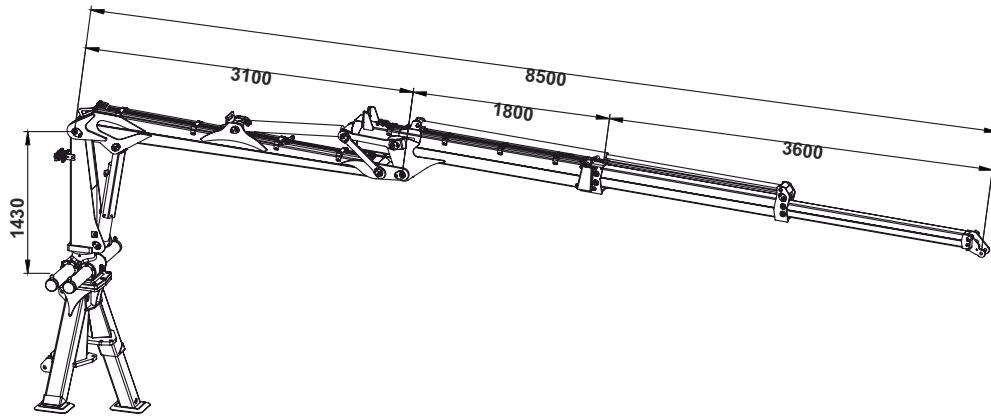

CRANE 850 Pro



	850 Pro
Max reach (m)	8,5
Lifting torque gross (kNm)	57
Lifting capacity at 3,5 m w/o rotator and grapple (kg)	1195
Lifting capacity at full reach w/o rotator and grapple (kg)	482
Slewing torque (kNm)	16
Slewing cylinders (pcs)	4
Slewing angle	380
Rotator max axial load (kN)	40
Telescope extension (pcs)	2
Telescopic boom stroke length (m)	3,6
Working pressure (bar)	190
Crane's weight without support legs and valve block (kg)	857
Recommended pump capacity (l/min)	50-65
Support legs type	A or FD pro
A type (telescopic) support legs weight, kg	319
FD type SMART (flap down) support legs weight, kg	-
FD type MASTER (flap down) support legs weight, kg	-
FD type PRO (flap down) support legs weight, kg	420
Recommended grapple size (m2)	0,22 to 0,26

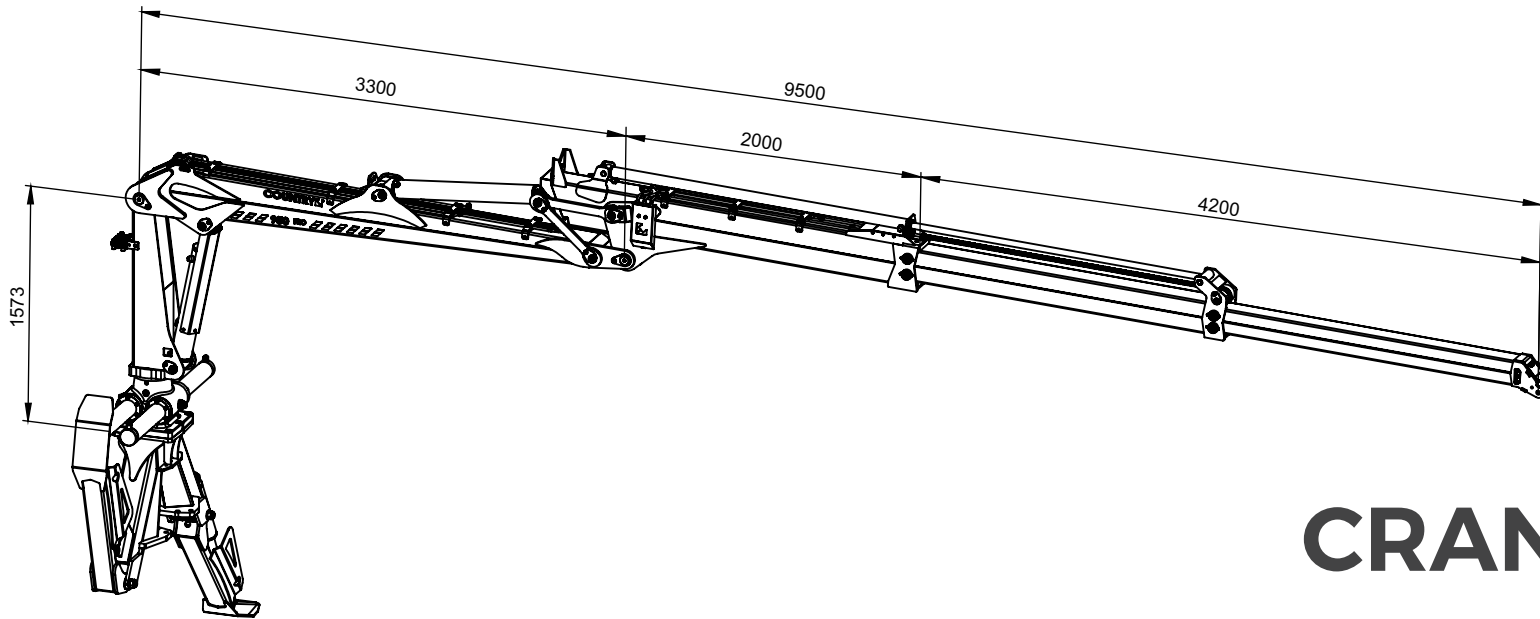

CRANE 950 Pro

	950 Pro
Max reach (m)	9.5
Lifting torque gross (kNm)	86
Lifting capacity at 3,5 m w/o rotator and grapple (kg)	1536
Lifting capacity at full reach w/o rotator and grapple (kg)	566
Slewing torque (kNm)	21,5
Slewing cylinders (pcs)	4
Slewing angle	380
Rotator max axial load (kN)	55
Telescope extension (pcs)	2
Telescopic boom stroke length (m)	4,2
Working pressure (bar)	200
Crane's weight without support legs and valve block (kg)	1318
Recommended pump capacity (l/min)	60-100
Support legs type	FD Pro
A type (telescopic) support legs weight, kg	-
FD type SMART (flap down) support legs weight, kg	-
FD type MASTER (flap down) support legs weight, kg	-
FD type PRO (flap down) support legs weight, kg	420
Recommended grapple size (m ²)	0,26



Trailers technical specifications

	15S	30S	50S	70S	90S	90D	110S
Max load (kg)	1500	3000	5000	7000	9000	9000	11000
Total length (mm)	3870	5340	5655	5625	6240	6200	6200
Total width with standard wheels (mm)	1290	1540	1775	2000	2150	2230	2290
Standard wheels	22.0/11-8	10.0/80-12	400/60-15,5	400/60-15,5	400/60-15,5	400/60-15,5	500/50-17
Length of loading area (mm)	2700	3000	3600	3500	3880	3900	3850
Loading area (m ²)	0.65	1.0	1.35	1.5	2.1	2,1	2.5
Chassis (mm)	80x80	100x100	120x120	140x140	160x160	2(200x100)	200x200
4 WD (roller drive between wheels)	Option	-	-	-	Option	Option	Option
2 WD (inner drum drive)	-	-	-	-	Option	Option	Option
Hydraulic brakes	-	Option	Option	Option	Option	Option	Option
Pneumatic brakes	-	-	-	-	Option	Option	Option
Overrun brakes	Option	Option	Option	Option	Option	Option	Option
Drawbar steering cylinders (pcs)	-	1 or 2	1 or 2	1 or 2	2	2	2
Max allowed crane (kNm)	15	25	30	40	60	60	70
Trailer weight w.o crane and wheels (kg)	170	380	740	820	1220	1548	1450

Cranes technical specifications

	410 Smart	500Smart	430 Master	550 Master	670 Master	700 Pro	720Pro	750Pro	850 Pro	950 Pro
Max reach (m)	4.1	5.0	4.3	5.5	6.7	7.0	7.2	7.5	8.5	9.5
Lifting torque gross (kNm)	12	23	27	27	39	50	57	86	57	86
Lifting capacity at 3,5 m w/o rotator and grapple (kg)	280	550	660	618	870	1120	1356	1898	1195	1536
Lifting capacity at full reach w/o rotator and grapple (kg)	180	382	538	390	451	560	625	886	482	566
Slewing torque (kNm)	2 or 4	6.3	7.8	7.8	12	15	16	21,5	16	21,5
Slewing cylinders (pcs)	2 or 4	4	4	4	4	4	4	4	4	4
Slewing angle	360	370	370	370	380	380	380	380	380	380
Rotator max axial load (kN)	10	30	30	30	30	40	40	55	40	55
Telescope extension (pcs)	1	1	-	1	1	1	1	1	2	2
Telescopic boom stroke length (m)	0.9	1.1	-	1.3	1.7	1.8	2.1	2,1	3,6	4,2
Working pressure (bar)	175	180	180	180	190	190	190	200	190	200
Crane's weight without support legs and valve block (kg)	167	315	335	375	565	690	780	1121	857	1318
Recommended pump capacity (l/min)	5-15	15-30	20-35	20-35	30-45	40-55	50-65	60-100	50-65	60-100
Support legs type	FD	A or FD	FD	FD	A or FD	A or FD	A or FD Pro	FD Pro	A or FD pro	FD Pro
A type (telescopic) support legs weight, kg	-	92	-	-	319	319	319	-	319	-
FD type SMART (flap down) support legs weight, kg	60	91	-	-	-	-	-	-	-	-
FD type MASTER (flap down) support legs weight, kg	-	-	135	135	338	338	-	-	-	-
FD type PRO (flap down) support legs weight, kg	-	-	-	-	420	420	420	420	420	420
Recommended grapple size (m2)	0.08	0.12	0.12 to 0.17	0.12 to 0.17	0.17 to 0.22	0.22 to 0.26	0.22 to 0.26	0,26	0.22 to 0.26	0,26

Trailers technical specifications

	110D	130D	150D	90SU	110DU	130DU	150DU
Max load (kg)	11000	13000	15000	9000	11000	13000	15000
Total length (mm)	6360	6470	6520	6240	6360	6470	6520
Total width with standard wheels (mm)	2280	2390	2450	2150	2280	2390	2450
Standard wheels	500/50-17	500/50-17	500/50-17	400/60-15,5	500/50-17	500/50-17	500/50-17
Length of loading area (mm)	4045	4150	4190	3880	4045	4150	4190
Loading area (m ²)	2,5	2,85	3,2	2,1	2,5	2,85	3,2
Chassis (mm)	2(200x100)	2(200x120)	2(200x120)	160x160	2(200x100)	2(200x120)	2(200x120)
4 WD (roller drive between wheels)	Option	Option	Option	Option	Option	Option	Option
2 WD (inner drum drive)	Option	Option	Option	Option	Option	Option	Option
Hydraulic brakes	Option	Option	Option	Option	Option	Option	Option
Pneumatic brakes	Option	Option	Option	Option	Option	Option	Option
Overrun brakes	Option	-	-	Option	Option	-	-
Drawbar steering cylinders (pcs)	2	2	2	2	2	2	2
Max allowed crane (kNm)	75	80	80	60	75	80	80
Trailer weight w.o crane and wheels (kg)	1620	1770	1905	1380	1845	1990	2130

COUNTRY forest trailers models names consist of a number and a letter. For example:

TRAILER 130D
D = double beam
130 = 13,000kg

TRAILER 90S
S = single beam
90 = 9,000kg

TRAILER 110DU
110 = 11,000kg
D = Double beam
U = U-loading area



TRAILER 15S / 30S

	15S	30S
Max load (kg)	1500	3000
Total length (mm)	3870	5340
Total width with standard wheels (mm)	1290	1540
Standard wheels	22.0/11-8	10.0/80-12
Length of loading area (mm)	2700	3000
Loading area (m ²)	0.65	1.0
Chassis (mm)	80x80	100x100
4 WD (roller drive between wheels)	Option	-
2 WD (inner drum drive)	-	-
Hydraulic brakes	-	Option
Pneumatic brakes	-	-
Overrun brakes	Option	Option
Drawbar steering cylinders (pcs)	-	1 or 2
Max allowed crane (kNm)	15	25
Trailer weight w.o crane and wheels (kg)	170	380
Recommended with cranes	410	500

15S

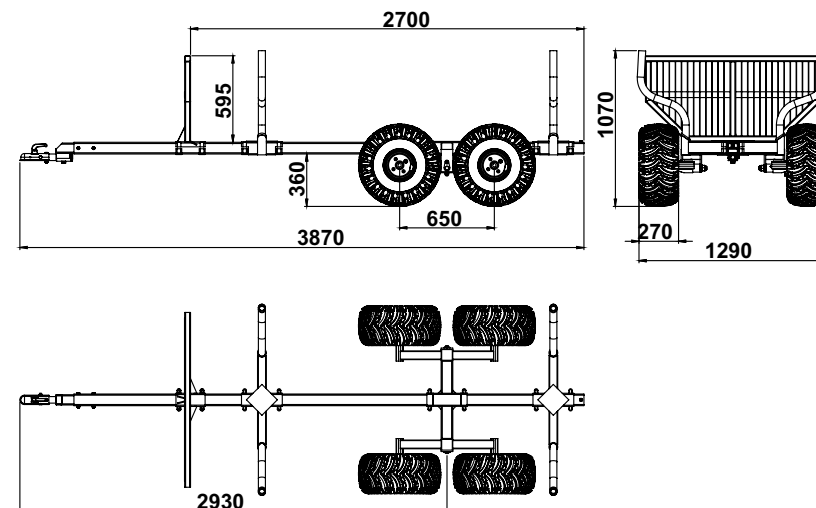

30S

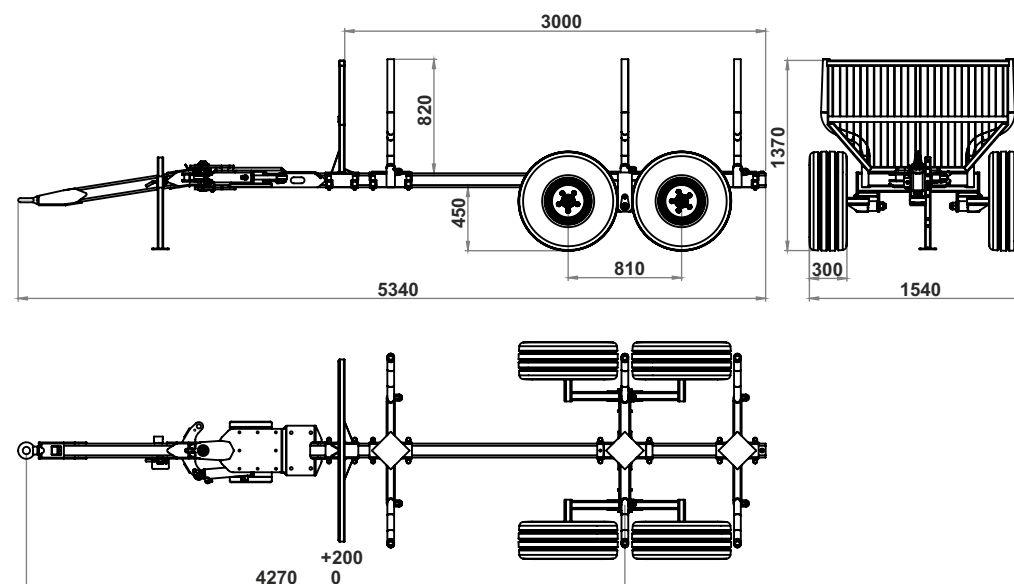

50S

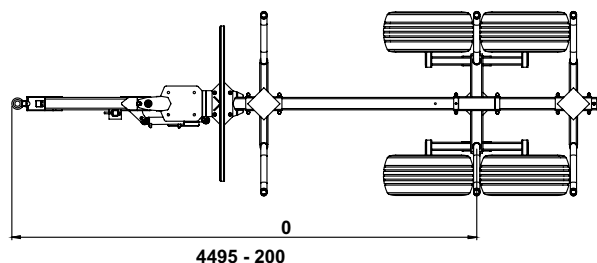
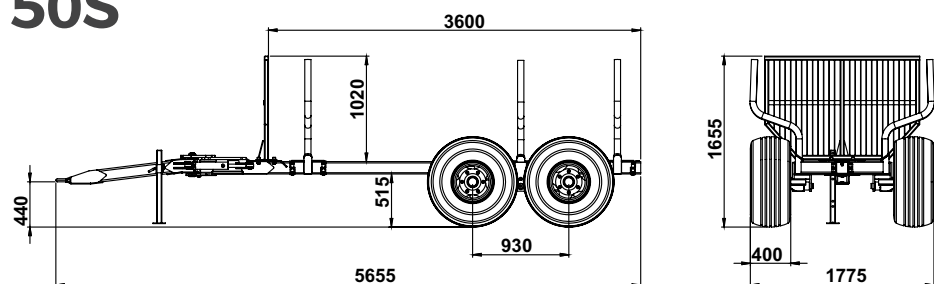

70S

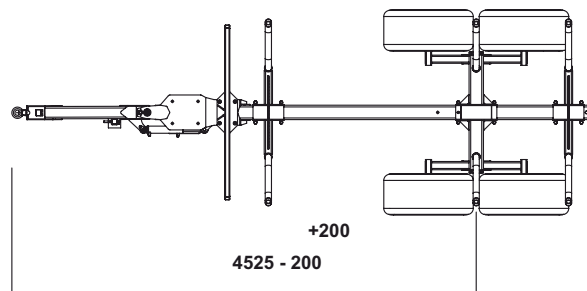
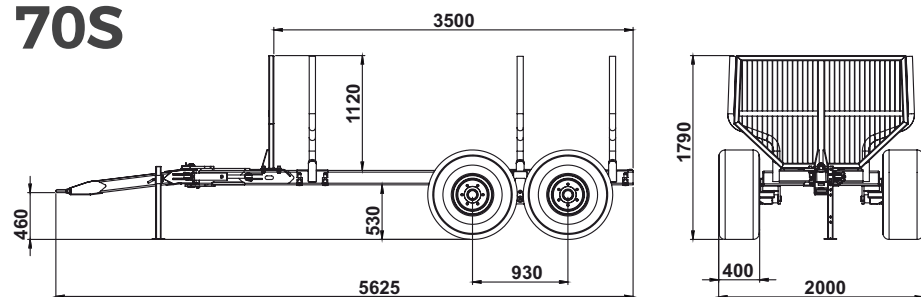

TRAILER 50S / 70S

	50S	70S
Max load (kg)	5000	7000
Total length (mm)	5655	5625
Total width with standard wheels (mm)	1775	2000
Standard wheels	400/60-15,5	400/60-15,5
Length of loading area (mm)	3600	3500
Loading area (m ²)	1.35	1.5
Chassis (mm)	120x120	140x140
4 WD (roller drive between wheels)	-	-
2 WD (inner drum drive)	-	-
Hydraulic brakes	Option	Option
Pneumatic brakes	-	-
Overrun brakes	Option	Option
Drawbar steering cylinders (pcs)	1 or 2	1 or 2
Max allowed crane (kNm)	30	40
Trailer weight w.o crane and wheels (kg)	740	820
Recommended with cranes	430/550	430/550/670



TRAILER 90D / 110D

	90D	110D
Max load (kg)	9000	11000
Total length (mm)	6200	6360
Total width with standard wheels (mm)	2230	2280
Standard wheels	400/60-15,5	500/50-17
Length of loading area (mm)	3900	4045
Loading area (m ²)	2,1	2,5
Chassis (mm)	2(200x100)	2(200x100)
4 WD (roller drive between wheels)	Option	Option
2 WD (inner drum drive)	Option	Option
Hydraulic brakes	Option	Option
Pneumatic brakes	Option	Option
Overrun brakes	Option	Option
Drawbar steering cylinders (pcs)	2	2
Max allowed crane (kNm)	60	75
Trailer weight w.o crane and wheels (kg)	1548	1620
Recommended with cranes	670/700 720/850	670/700 720/850

90D

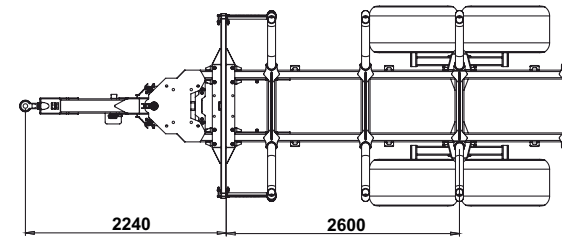
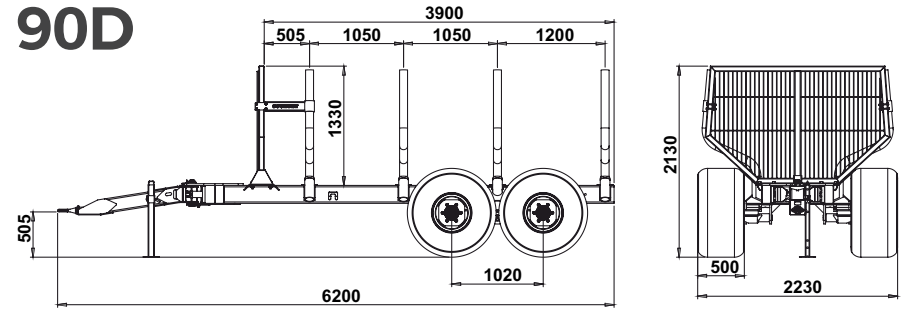

110D

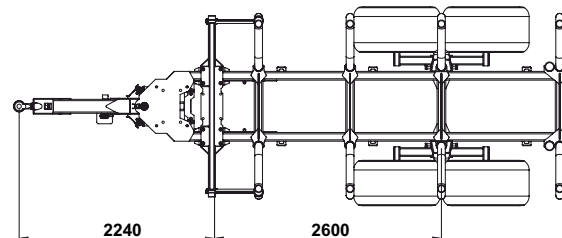
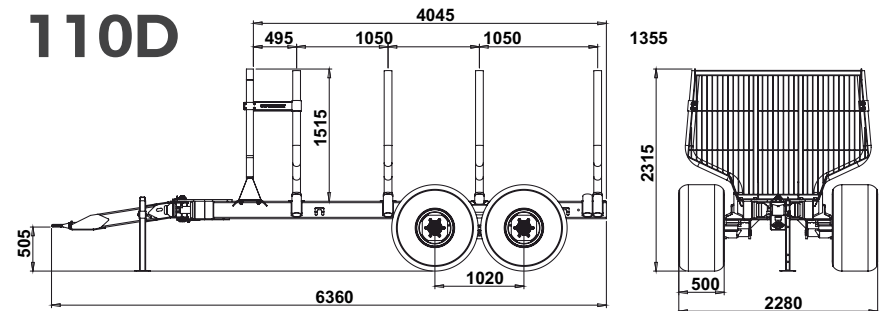

90S

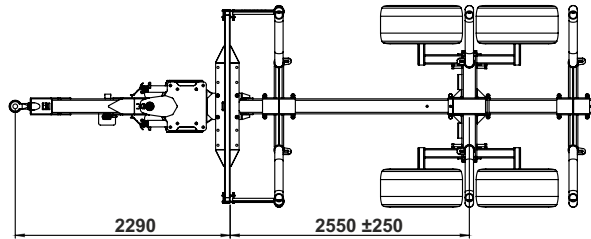
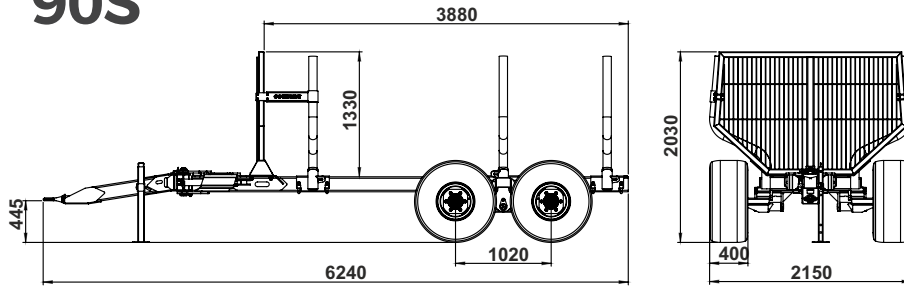

110S

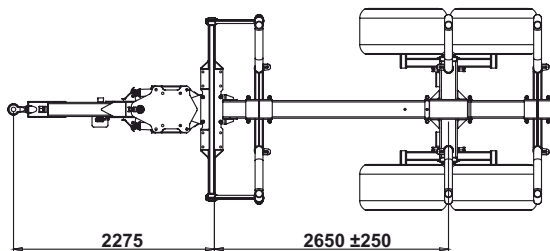
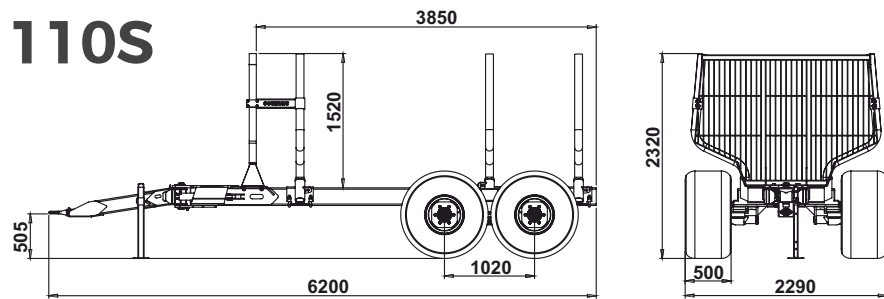

TRAILER 90S / 110S

	90S	110S
Max load (kg)	9000	11000
Total length (mm)	6240	6200
Total width with standard wheels (mm)	2150	2290
Standard wheels	400/60-15,5	500/50-17
Length of loading area (mm)	3880	3850
Loading area (m ²)	2.1	2.5
Chassis (mm)	160x160	200x200
4 WD (roller drive between wheels)	Option	Option
2 WD (inner drum drive)	Option	Option
Hydraulic brakes	Option	Option
Pneumatic brakes	Option	Option
Overrun brakes	Option	Option
Drawbar steering cylinders (pcs)	2	2
Max allowed crane (kNm)	60	70
Trailer weight w.o crane and wheels (kg)	1220	1450
Recommended with cranes	670/700 720/850	670/700 720/850



TRAILER 110DU/90SU

	110DU	90SU
Max load (kg)	11000	9000
Total length (mm)	6360	6240
Total width with standard wheels (mm)	2280	2150
Standard wheels	500/50-17	400/60-15,5
Length of loading area (mm)	4045	3880
Loading area (m ²)	2.5	2.1
Chassis (mm)	2(200x100)	160x160
4 WD (roller drive between wheels)	Option	Option
2 WD (inner drum drive)	Option	Option
Hydraulic brakes	Option	Option
Pneumatic brakes	Option	Option
Overrun brakes	Option	Option
Drawbar steering cylinders (pcs)	2	2
Max allowed crane (kNm)	75	60
Trailer weight w.o crane and wheels (kg)	1845	1380
Recommended with cranes	670/700	670/700
	720/850	720/850

110DU

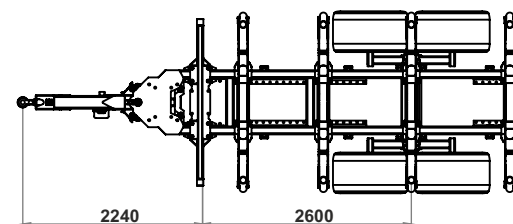
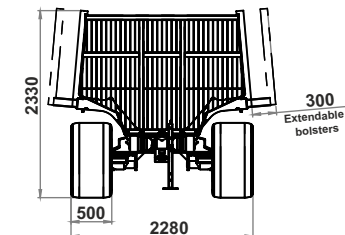
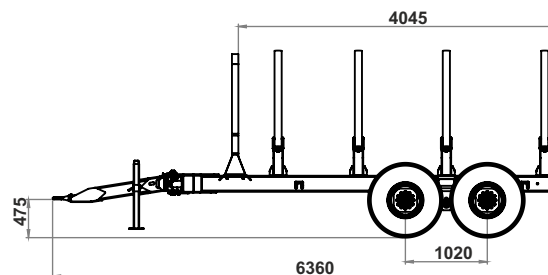

90SU

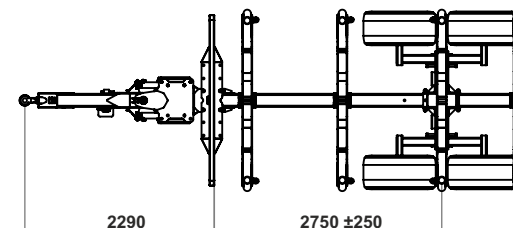
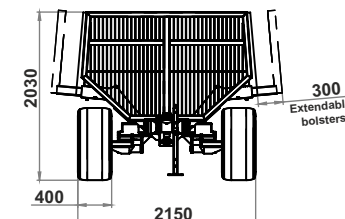
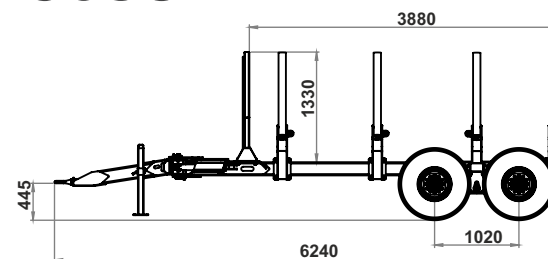



130D

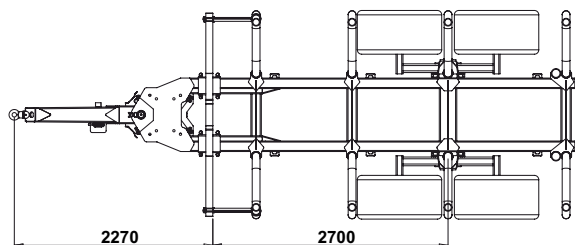
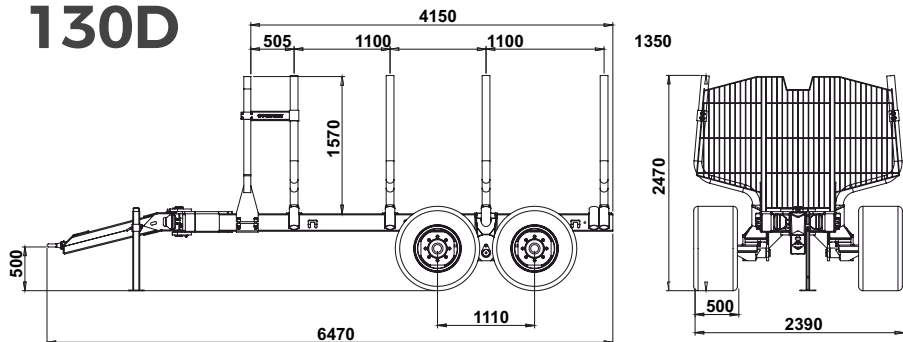

150D

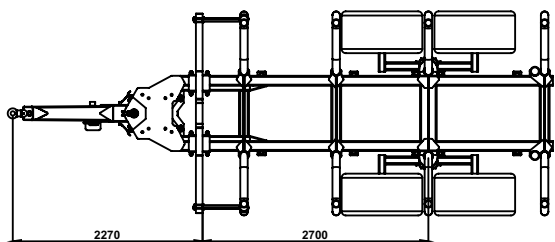
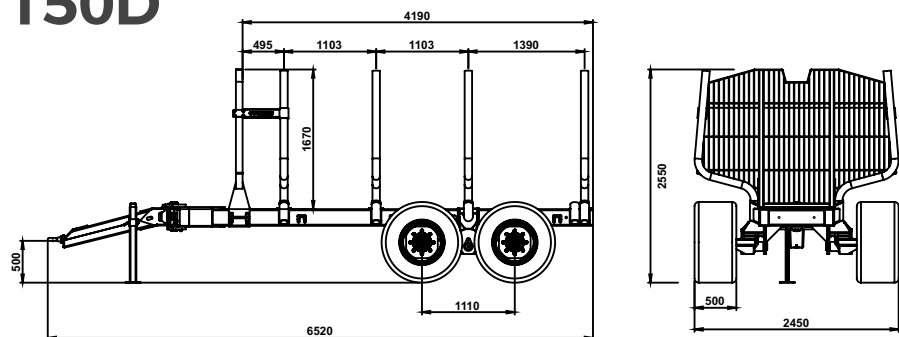

TRAILER 130D / 150D

	130D	150D
Max load (kg)	13000	15000
Total length (mm)	6470	6520
Total width with standard wheels (mm)	2390	2450
Standard wheels	500/50-17	500/50-17
Length of loading area (mm)	4150	4190
Loading area (m ²)	2,85	3,2
Chassis (mm)	2(200x120)	2(200x120)
4 WD (roller drive between wheels)	Option	Option
2 WD (inner drum drive)	Option	Option
Hydraulic brakes	Option	Option
Pneumatic brakes	Option	Option
Overrun brakes	-	-
Drawbar steering cylinders (pcs)	2	2
Max allowed crane (kNm)	80	80
Trailer weight w.o crane and wheels (kg)	1770	1905
Recommended with cranes	670/700/720 750/850/950	670/700/720 750/850/950



TRAILER 130DU / 150DU

	130DU	150DU
Max load (kg)	13000	15000
Total length (mm)	6470	6520
Total width with standard wheels (mm)	2390	2450
Standard wheels	500/50-17	500/50-17
Length of loading area (mm)	4150	4190
Loading area (m ²)	2,85	3,2
Chassis (mm)	2(200x120)	2(200x120)
4 WD (roller drive between wheels)	Option	Option
2 WD (inner drum drive)	Option	Option
Hydraulic brakes	Option	Option
Pneumatic brakes	Option	Option
Overrun brakes	-	-
Drawbar steering cylinders (pcs)	2	2
Max allowed crane (kNm)	80	80
Trailer weight w.o crane and wheels (kg)	1990	2130
Recommended with cranes	670/700/720 750/850/950	670/700/720 750/850/950

130DU

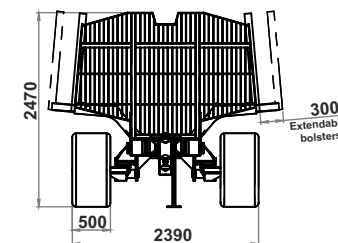
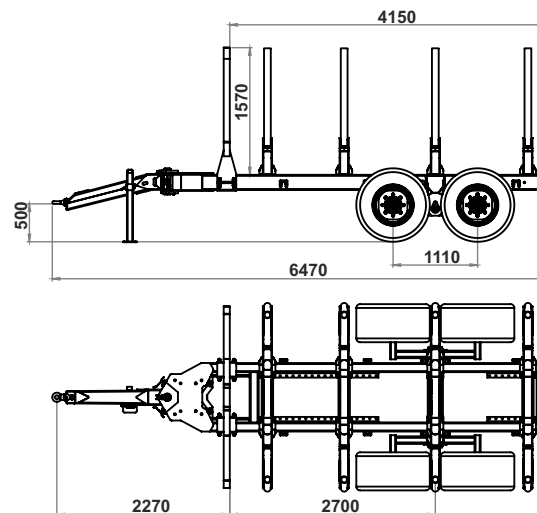

150DU

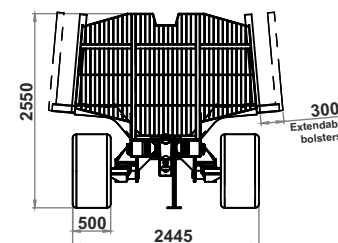
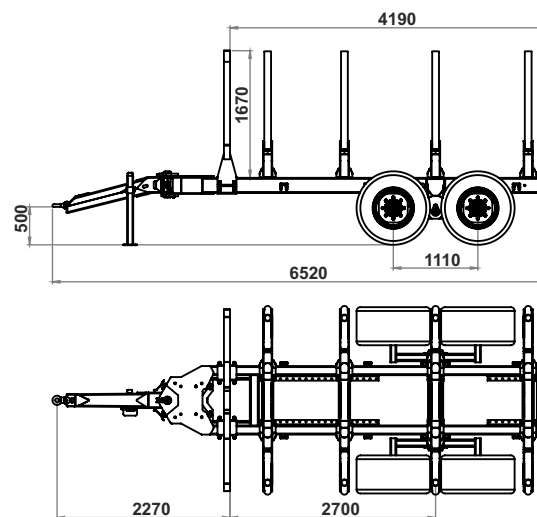

Cranes and trailers compatibility

	410 Smart	500 Smart	430 Master	550 Master	670 Master	700 Pro	720 Pro	750 Pro	850 Pro	950 Pro
15S	X									
30S		X	X	X						
50S		X	X	X						
70S		X	X	X	X					
90S					X	X	X		X	
90SU					X	X	X		X	
90D					X	X	X		X	
110S					X	X	X		X	
110DU					X	X	X		X	
110D					X	X	X		X	
130D					X	X	X	X	X	X
130DU					X	X	X	X	X	X
150D					X	X	X	X	X	X
150DU					X	X	X	X	X	X

Accessories



Dumper box



Earth bucket



Forest rim



Hydraulic unit



LED lights on crane



Toolbox

COUNTRY 
Accessories



Air brakes



Hydraulic brakes



Overrun brakes



Foldable lights



Kilpi lights



2wd/4wd BlackBruin



4wd roller drive



Brakelink for rotator



Flange rotator



Oil tank

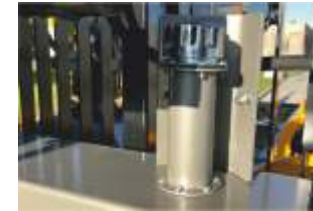

Oil tank cap extension



PTO piston pump



Telescopic extension



Extra posts



Standing platform



Standing platform
with pump



Radio-winch 1400 & 2200



Radio-winch 500 & 1000

Control valves



Pre-Hydraulic



Propo elctrical



Propo electrical
mini-levers



Remote control



5/7-XY

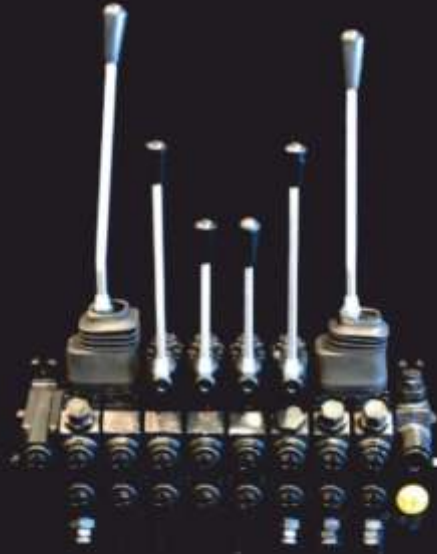

6/8-XY



4/8-on-off

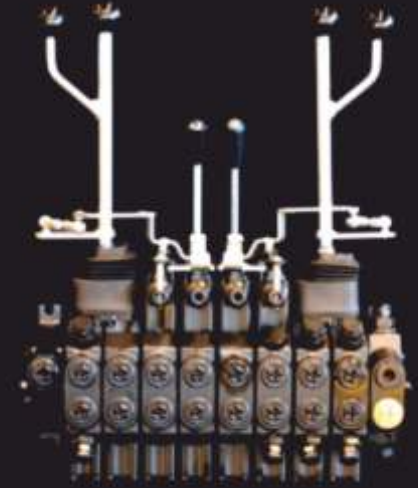

4/8-XYZ

All Pro series cranes:

Crane frames are made of **STRENX**

All pins 42CrMo4

Powder coated

Oil inspection window in turning house

Gear rack 42CrMo4

Turning house body made from nodular cast iron EN-GJS 500-14

Extra strong PRO series supportlegs

Pro series grapples:

Brake link

Rotator hoses hidden inside the telescope

Made of **STRENX**

Bronze bearings

All pins 42CrMo4

Main boom cylinder protection

Expandable loading area

Trailers:

Frame made from S420

U-type frames made of **STRENX**

Special forest wheels

Bolsters 89x8

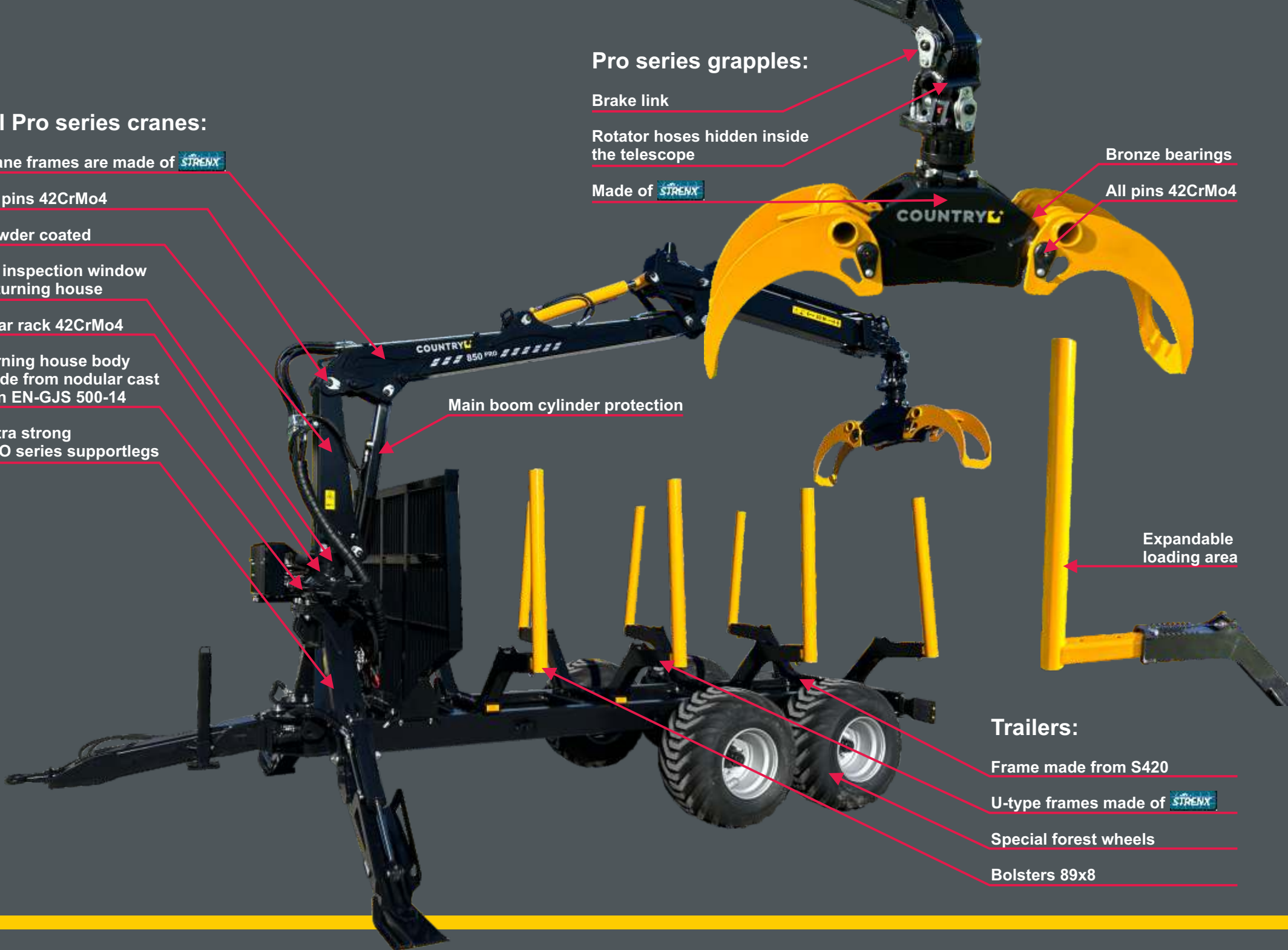



Reseller

Manufacturer

COUNTRY ®

COUNTRY OÜ
Reg.nr: 12565983

Selja tee 17, Kunda
44105 Lääne-Virumaa

Estonia

Tel: +372 50 56 120
Tel: +372 50 62 604

E-mail: orders@country.ee

www.country.ee